



www.faleemi.com



support@faleemi.com



youtube.com/c/Faleemi



support@faleemi.com



www.facebook.com/faleemicamera



twitter.com/faleemi

© Faleemi Technologies Ltd or its affiliates. All rights reserved.

No part of this publication may be reproduced or transmitted in any form or by any means or used to make any derivative work (such as translation, transformation, or adaptation) without written permission from Faleemi Technologies Ltd ("Faleemi"). Faleemi reserves the right to revise this publication and to make changes in content from time to time without obligation on the part of Faleemi to provide notification of such revision or change.

Faleemi provides this guide without warranty of any kind, implied or expressed, including, but not limited to, the implied warranties of merchantability and fitness for a particular purpose. Faleemi may make improvements or changes in the product(s) described in this manual at any time.

The capabilities, system requirements and/or compatibility with third-party products described herein are subject to change without notice.

Version.04.2019



Made in China

Faleemi and the Faleemi logo are all trademarks or registered trademarks of Faleemi Technologies Ltd. Other trademarks and trade names may be used in this document to refer to either the entities claiming the marks and the names of their products. Faleemi disclaims proprietary interest in the marks and names of others.

Apple®, Apple Store®, iPad®, iPhone®, MAC® (Text, Logo, Picture) are trademarks of Apple, Inc.

Android®, Google Play® (Text, Logo, Picture) are trademarks of Google Inc.

Samsung® (Text, Logo, Picture) is a registered trademark of Samsung Electronics Co., Ltd.

Skype® (Text, Logo, Picture) is a registered trademark of Microsoft Corporation

Facebook® (Text, Logo, Picture) is a registered trademark of Facebook, Inc.

Twitter® (Text, Logo, Picture) is a registered trademark of Twitter, Inc.

Micro SD® text and logo are the trademark of SD-3C, LLC.

Wi-Fi® is a registered trademark of the Wi-Fi Alliance.

All other products, names or companies are the brands or registered trademarks of their respective owners.



Quick Start Guide

FSC861



We at Faleemi are committed to do our part in protecting our environment. In this continuing effect, we have supplied the detailed manuals, documentation, software, troubleshooting and video guides on our website.

www.faleemi.com/support



Thank You

Dear Customer,

Thank you for choosing Faleemi among all the brands. We hope our products will protect your home and give you peace of mind.

At Faleemi, we truly care about our customers' Purchase Experience and User Experience, so "Customer satisfaction guaranteed is our goal". We are 100% dedicated to your complete satisfaction.

If your experience has been something less than amazing, or need additional information, please drop us an email at support@faleemi.com. Or you are welcome to visit our website www.faleemi.com/faq for more information. Please do remember that we are always more than happy to ensure you're a HAPPY Customer.

As a growing company, we are improving all aspects of our service and products. If you got any suggestion or comment, welcome to let us know. We will continue to improve and provide our customers with quality products and service.

Yours sincerely,
Team Faleemi



www.faleemi.com



support@faleemi.com



[youtube.com/c/Faleemi](https://www.youtube.com/c/Faleemi)



[facebook.com/faleemicamera](https://www.facebook.com/faleemicamera)

Contents

Product information	1
Download APP and Getting started	2
Setup Option A: Add the cameras via Lan Search Recommended	3
Setup Option B: Add the cameras via wired mode Recommended	7
Setup Option C: Add cameras via WiFi configuration guide	11
Live Video Interface	15
Installation.....	16
How to connect the camera to the second Phone?	17
Advanced Settings	19
How to do the settings for receiving message alert on your phone?	20
[Push Setting]	20
[Alarm Event]	21
[Notifications]	22
How to set it to record constantly to the memory card?	23
How to record alarm video to the memory card?	24
How to view the recorded video on memory card?	25
How do i change my camera password?	26
Trouble Shooting Frequently Asked Questions	27
1. How to reset your camera (restore to factory default)?	27
2. Timer Restart option	28
3. Multi-view	28
4. How do I change my video stream resolution?	29
5. How do I flip my camera's video stream?	29
6. How do I find the WiFi MAC address of my camera?	29
7. If I change the router, how do I reconnect the camera?	30
8. How do I change the WiFi SSID on my router?	30
9. How to set Faleemi camera IP Address and Port ?	31
10. How to set email alert?	31
11. How to link your camera to your PC/Mac by Faleemi Plus?	31

What's in the box?

- Faleemi Weatherproof WiFi Security IP Camera FSC861
- WiFi Antenna
- Power Adapter
- Network Cable
- Mounting Screws & Plugs
- Hex Key
- Weatherproof Connector
- Quick Start Guide

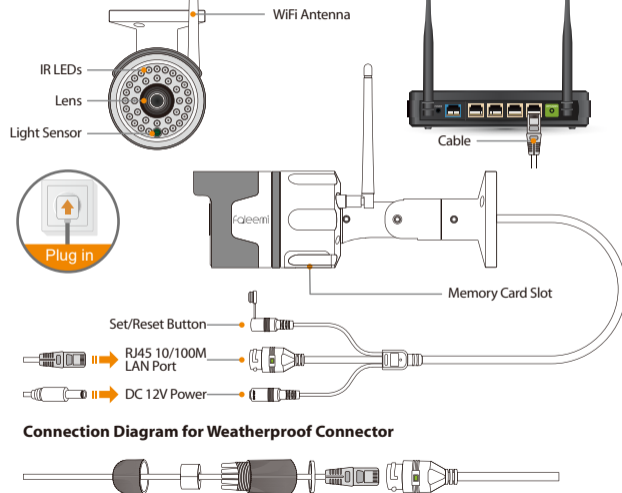
**Connections****Download the Faleemi APP (Android / iOS) before doing the setup**

Connect your mobile device to your WiFi and download the App "Faleemi" from the App Store or Google Play store, or scan below QR code to download it.

**Before configuring your camera, please read the points below.**

- Please use the included Ethernet cable to connect your camera to your router before performing the setup. After the camera is connected to your WiFi, you can relocate it to where you want. You just unplug it and move it to the new location and plug it in, it will connect to your WiFi automatically, no need to set it up again.
- Please make sure your phone is connected to your **2.4GHz WiFi (not cellular data and 5GHz WiFi)** before doing the setup. Your 2.4GHz WiFi name (SSID) must be different from your 5.0GHz one. Please make sure your WiFi name and password do not have the special characters "&" and "' (apostrophe). If you are not sure, please go to your router settings to find this out.
Note: THIS WILL NOT AFFECT THE 5GHz WIFI USE OF YOUR OTHER WIRELESS DEVICES :)
- If you don't know how to go to your router settings, please visit our website www.faleemi.com/blocks/router to find the instructions or contact us at support@faleemi.com.
- If you don't see the **green light** , please do a "Factory Reset". This process is outlined on **Page 27** of this manual. ["1. How to reset your camera (restore to factory default)?"].

Now, please follow below instructions to get your camera set up.

Setup Option A: Step 1 / Add the cameras via Lan Search

1. Please plug the camera in with the included power supply, and connect the camera to your router with the included Ethernet cable.

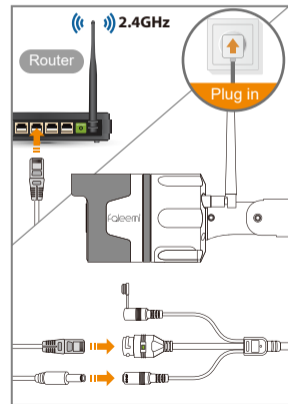

2. Open the Faleemi App, Click on [Add Camera].

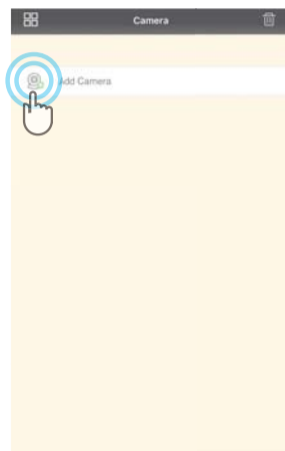

3. Click on [Add the cameras which are already connected to your WiFi network].

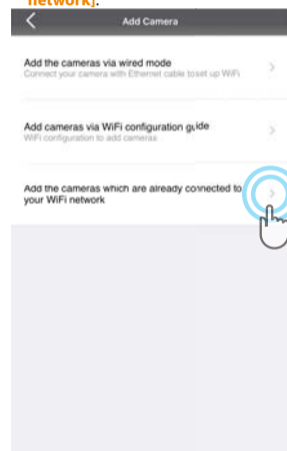

4. Click on [LAN Search].

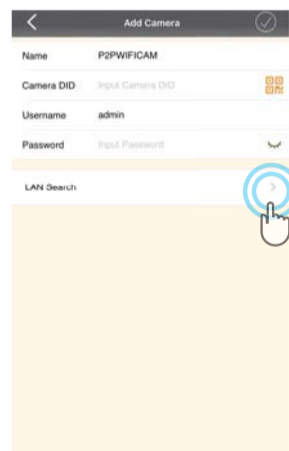

5. Click on the camera searched.

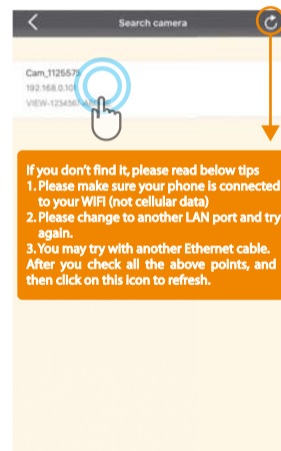

6. Give your camera a name, and input Password 123456, click on [✓]. It will take you to the home page.

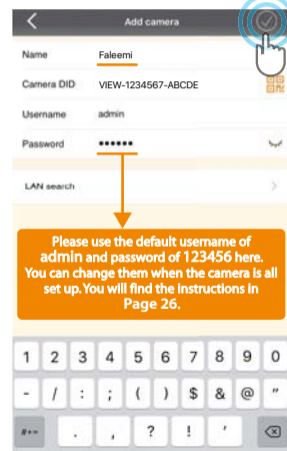

Step 2 / WiFi Connection

1. Click on the icon [>].



2. Click on [Advanced Settings].

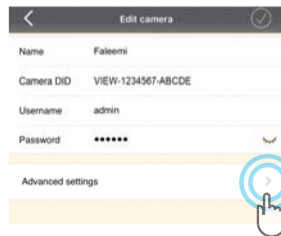

3. Click on [WiFi Settings].

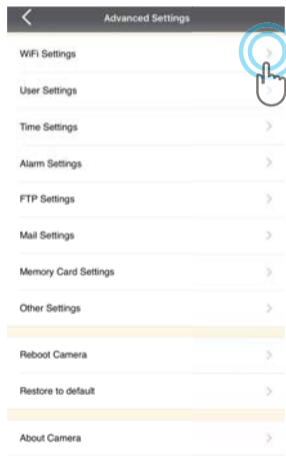

4. Choose 2.4GHz WiFi to connect.



5. Input your 2.4GHz WiFi password and click on [✔].



6. It will say [Set Succeeded!]. It means the camera is connected to your WiFi, please remove the Ethernet cable.



7. You will see it says the camera is Online. Congratulations! Your camera is all set up. Click on the image to enjoy viewing and controlling it now.

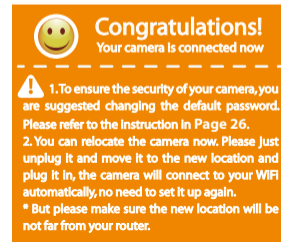
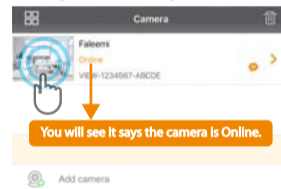

🔧 Troubleshooting

1. If the connection was failed, the WiFi password you just input may be wrong. Please reset the camera (instructions in Page 27) and do the setup again.

2. If your WiFi password was correct but still failed.

(a). Please make sure your phone is connected to your **2.4GHz WiFi** (not 5GHz WiFi) before doing the setup.

(b). Your 2.4GHz WiFi name (SSID) must be different from your 5.0GHz one.

(c). Please make sure your WiFi name and password do not have the special characters "&" and "' (apostrophe).

If you are not sure, please go to your router settings to find this out.

If you don't know how to go to your router settings, please visit our website

www.faleemi.com/blocks/router to find the instructions.

For more FAQ information, please visit

<https://www.faleemi.com/faq/>

Or contact us:

support@faleemi.com

Setup Option B: Add the cameras via wired mode

1. Please plug the camera in with the included power supply, and connect the camera to your router with the included Ethernet cable.

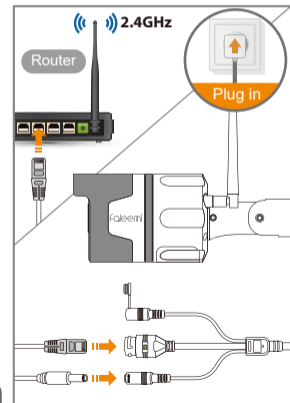

2. Open the Faleemi App, Click on **[Add Camera]**.

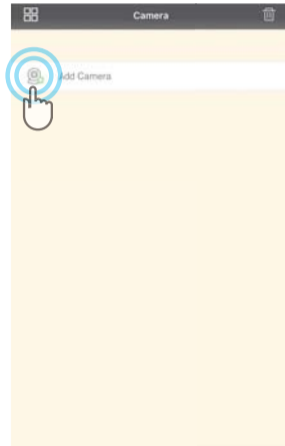

3. Click on **[Add the cameras via wired mode]**.

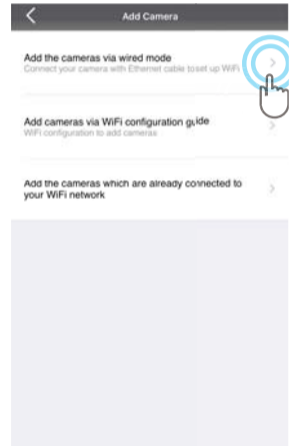

4. Click on **[Next]**.

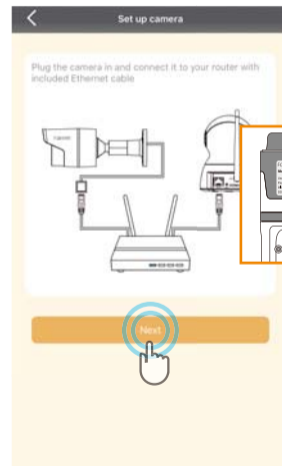

5. Please scan the QR Code at the bottom of the camera.



6. Type in the name you have selected for your camera and click on **[Next]**.

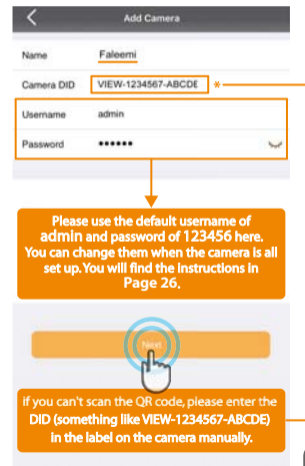

7. It says connection success, if you want to use wired connection, please click on **[Cancel]**; If you want to use WiFi, please click on **[OK]** to do the WiFi connection.

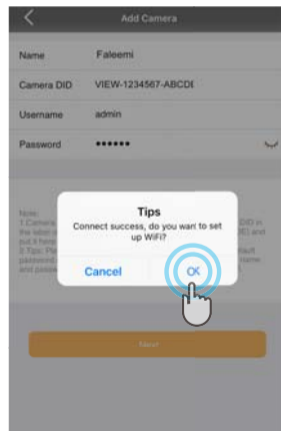

8. Choose **2.4GHz** WiFi to connect.

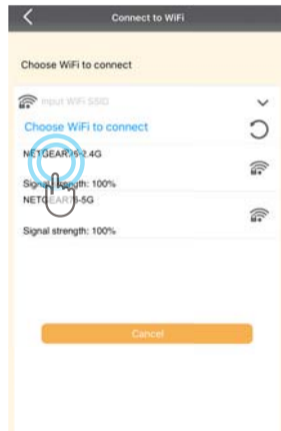

9. Input your **2.4GHz** WiFi password and click on **[Next]**.



10. It will say WiFi is set successfully. It means the camera is connected to your wifi, Click on **[OK]**, please remove the Ethernet cable.

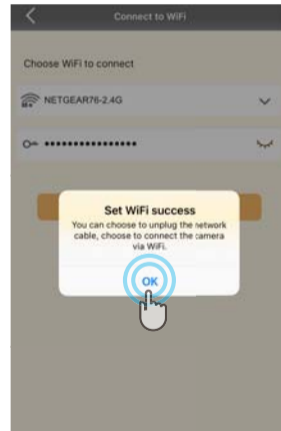

11. You will see it says the camera is **Online**. Congratulations! Your camera is all set up. **Click on the image** to enjoy viewing and controlling it now.

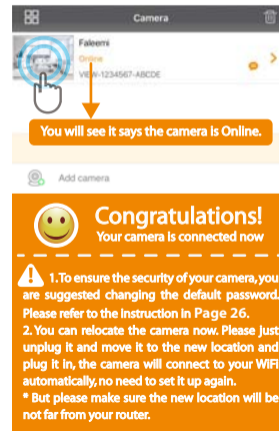

Troubleshooting

1. If the connection was failed, the WiFi password you just input may be wrong. Please reset the camera (instructions in **Page 27**) and do the setup again.

2. If your WiFi password was correct but still failed.

(a). Please make sure your phone is connected to your **2.4GHz WiFi** (not 5GHz WiFi) before doing the setup.

(b). Your 2.4GHz WiFi name (SSID) must be different from your 5.0GHz one.

(c). Please make sure your WiFi name and password do not have the special characters "**&**" and "**'**" (apostrophe).

If you are not sure, please go to your router settings to find this out.

If you don't know how to go to your router settings, please visit our website

www.faleemi.com/blocks/router to find the instructions.

For more FAQ information, please visit

<https://www.faleemi.com/faq/>

Or contact us:

support@faleemi.com

Setup Option C: Add cameras via WiFi configuration guide

1. Please **put your camera close to your WiFi router** and plug it in, and then you will see the green light is blinking slowly.

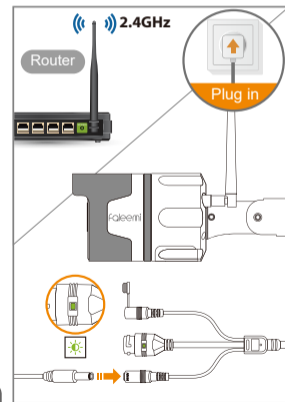
5 mins
NOTE

Only when it blinks green slowly , should you start to do the setup. It lasts **only 5 mins** after the camera is powered up.

If you don't do the setup in 5 mins, please unplug the camera and plug it in again to get another 5 mins setting time.

2. Open the Faleemi App, click on **[Add Camera]**.



3. Click on **[Add cameras via WiFi configuration guide]**.

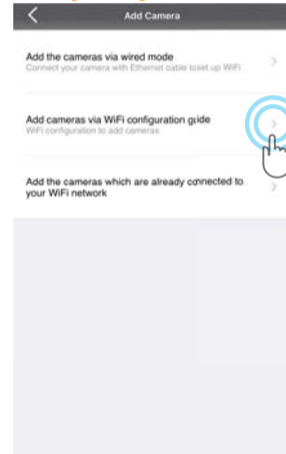

4. Please scan the QR Code at the bottom of the camera.

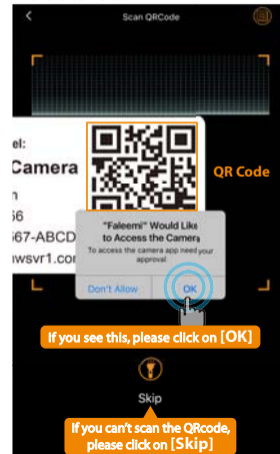

5. Click on **[The blue light is flashing slowly]**.



6. Type in the name you have selected for your camera and click on **[Next]**.

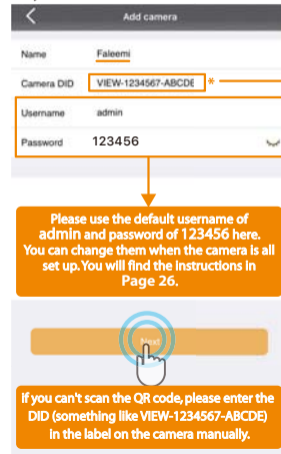

7. Input your 2.4GHz WiFi password and click on **[Connect to WiFi]**.



8. Click on **[Start]**.

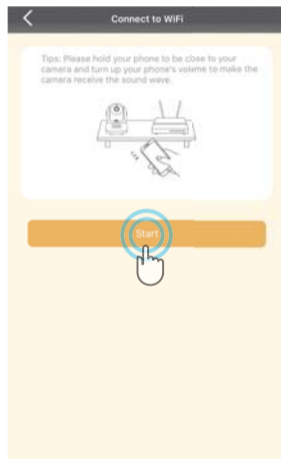

9. Connect to WiFi.



10. You will see it says the camera is **Online**. Congratulations! Your camera is all set up. **Click on the image** to enjoy viewing and controlling it now.

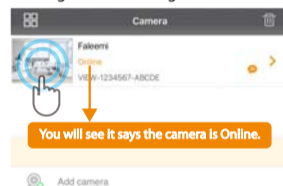

Congratulations!
Your camera is connected now

1. To ensure the security of your camera, you are suggested changing the default password. Please refer to the instruction in Page 26.
 2. You can relocate the camera now. Please just unplug it and move it to the new location and plug it in, the camera will connect to your WiFi automatically, no need to set it up again.
- * But please make sure the new location will be not far from your router.

Connect to WiFi

WiFi connection failed, check below trouble shootings

If the blue light is still flashing quickly, please click on Reconfigure button. Please double check the WiFi is 2.4GHz and the WiFi password is correct.

Restart

If the blue light goes off, you may type in a wrong WiFi password, or it is time out. (The setup time is 5 minutes). Please reset the camera (Hold down "Reset" button for about 15 seconds) and do the setup again.

Please try "Add the cameras via wired mode" to setup WiFi if your camera comes with Ethernet cable jack.

You're welcome to contact us at support@faleemi.com for help if it will still not be connected.

! If the setting is failed, please find below solution or contact us by

Email: support@faleemi.com

Skype: [support@faleemi.com](https://www.faleemi.com)

Phone: 213 293 3560

EDT: 6am~11am, 8pm~11pm

PDT: 6am~8am, 5pm~12pm

When you call us, please wait some more moment until we pick up the phone.

Troubleshooting

1. If the connection was failed, the WiFi password you just input may be wrong. Please reset the camera (instructions in Page 27) and do the setup again.
2. If your WiFi password was correct but still failed.
 - (a). Please make sure your phone is connected to your **2.4GHz WiFi** (not 5GHz WiFi) before doing the setup.
 - (b). Your 2.4GHz WiFi name (SSID) must be different from your 5.0GHz one.
 - (c). Please make sure your WiFi name and password do not have the special characters "&" and "'" (apostrophe).

If you are not sure, please go to your router settings to find this out.

If you don't know how to go to your router settings, please visit our website www.faleemi.com/blocks/router to find the instructions.

For more FAQ information, please visit <https://www.faleemi.com/faq/>

Or contact us:

support@faleemi.com

Live Video Interface

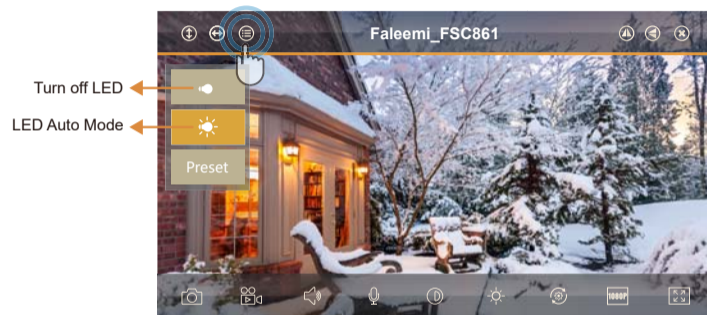

- | | | | |
|---------------------------|-------------------------|--------------------|--|
| Cruise Vertically (N/A) | Exit | Contrast | IR LED Off |
| Cruise Horizontally (N/A) | Snapshot to phone | Brightness | LED Auto Mode |
| Menu | Record video to phone | Restore to default | Preset Set or Call Preset (N/A) |
| Flip | Audio On/Off (N/A) | 480P/1080P | |
| Mirror | Microphone On/Off (N/A) | Contract | |

Installation

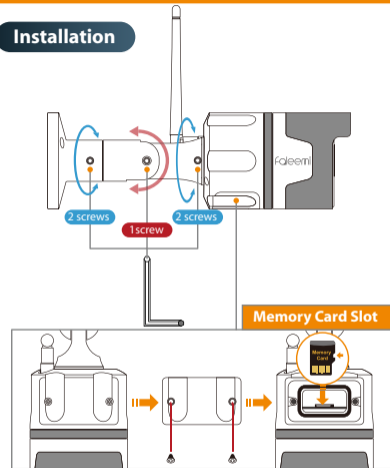

Please insert the Micro SD card as the above diagram.
Suggest using Micro SDHC/SDXC

(* MicroSD, MicroSDHC/SDXC text and logo are the trademark of SD-3C, LLC)

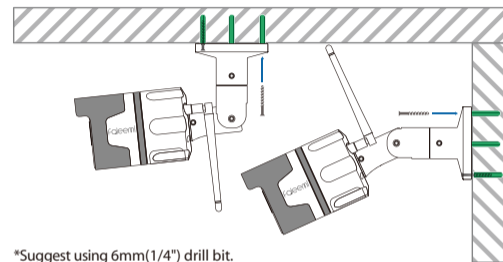

*Suggest using 6mm(1/4") drill bit.



- Mark the positions of the screw holes on the mounting surface.
- Drill holes and insert the anchors (included) as needed.
- Firmly attach the camera to the mounting surface using the included screws.
- Loosen the Screw by turning them counter clockwise with included hex key.
- Adjust the angle of the cameras until the desired view is set.
- Tighten the screws to secure camera's position.



Please install the camera after it is connected. Please pay attention to safety when you are installing it.

How to connect the camera to the second Phone?

After you use one phone to get your camera connected, if you would like to add your camera to the second phone, please follow below instructions to do the setup.

Option A Locally If your second phone can be connected to the same WiFi as your camera, please follow below instructions.

1. Download the Faleemi App to your second phone.
2. Open the Faleemi App, click on **[Add Camera]**.



3. Click on **[Add the cameras which are already connected to your WiFi network]**.



4. Click on **[LAN Search]**.

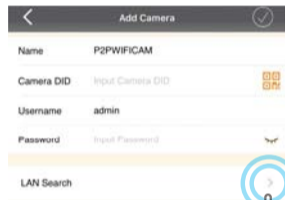

5. Click on the camera searched.

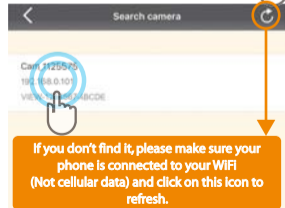

6. Give your camera a name, and input Password, click on **[✓]**. It will take you to the home page.

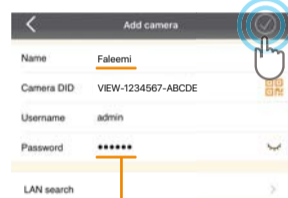
**Tips:**

Default (123456), but if you changed the password on your first phone, please enter your new password here.



Option B Remotely If your second phone can not be connected to the same WiFi, please follow below instructions.

1. Download the Faleemi App to your second phone.
2. Open the Faleemi App, click on **[Add Camera]**.



3. Click on **[Add the cameras which are already connected to your WiFi network]**.

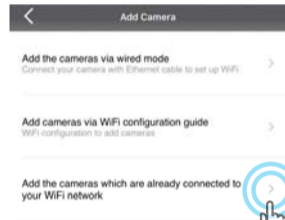

4. Please find your camera DID (something like **VIEW-1234567-ABCDE**) in your first phone or the label on the camera.

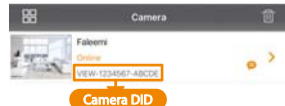

5. Give your camera a name, and input Camera DID, Password, click on **[✓]**. It will take you to the home page.

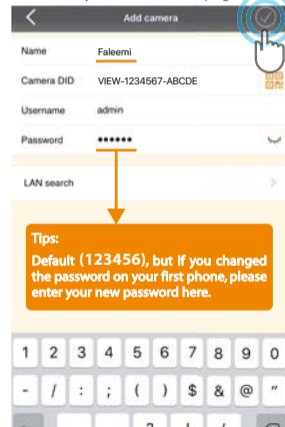

Advanced Settings

Please follow below steps to go to Advanced Settings to do more settings.

1. Click on the icon [>].

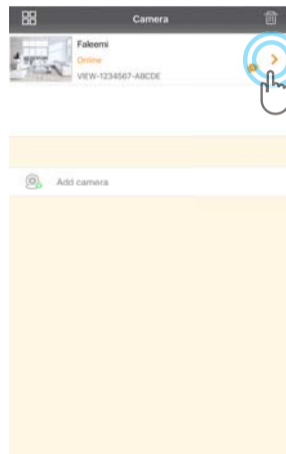

2. Click on [Advanced Settings].

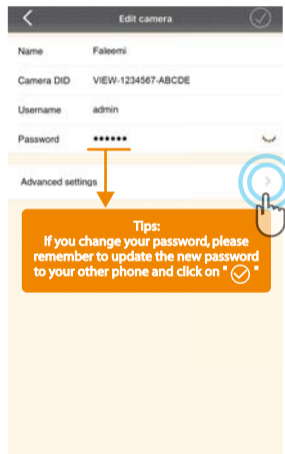

3. Do [Advanced Settings] here.

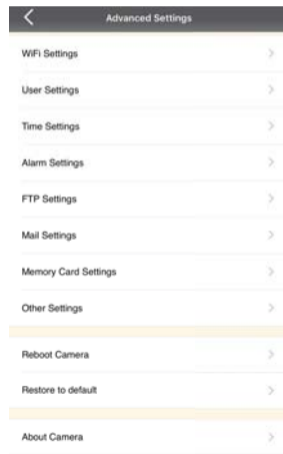

How to do the settings for receiving message alert on your phone?

[Alarm Settings]

1. Click on the icon [>].

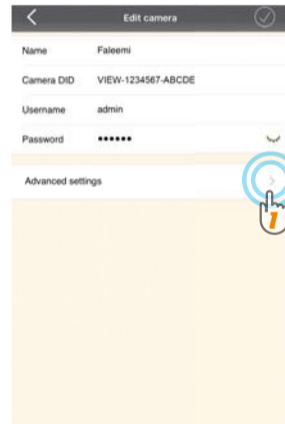

2. Click on [Alarm Settings].

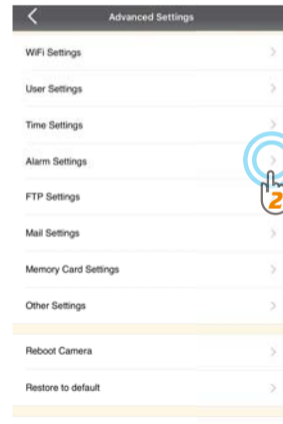

3. Enable [Motion Detection Alarm].

4. Click on [checkmark icon].

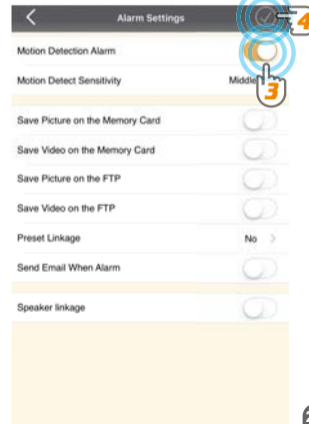

[Push Setting - iOS]

1. Click on **[More]**. 2. Click on **[Push Setting]**.

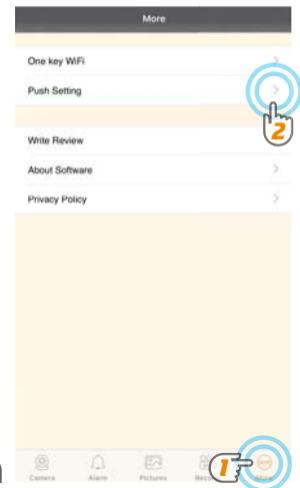

3. Find the camera you want to receive message alert and turn on the button **[Allow app receiving push message]**.

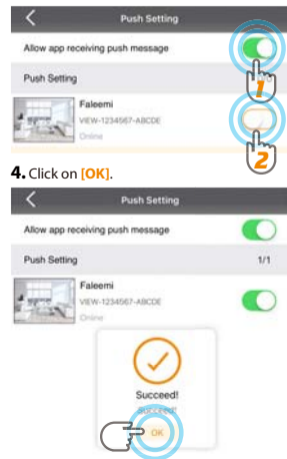

4. Click on **[OK]**.

[Push Setting - Android]

1. Click on the icon **[>]**.



2. Enable **[There is an alarm]**, **[Allow Push alarm]** 3. Click on **[✓]**.

**Alarm Event**

1. Click on **[Alarm]**. 2. Click on **[>]**.

**Notifications**

You will receive text messages when there's motion.

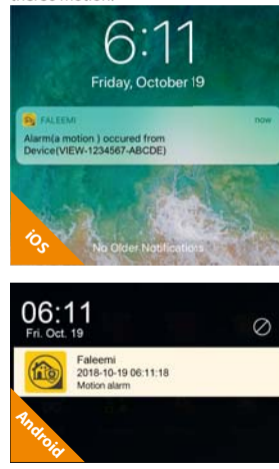

If you don't receive the message, please go to your phone's **[Settings]**—**[Notifications]**—**[Faleemi APP]** to check if you turn on the button **"Allow Notifications"**.



How to set it to record constantly to the memory card?

* Please follow the instruction in **Page 16** to insert the SD card and format your memory card before using.

1. Click on the icon [>].

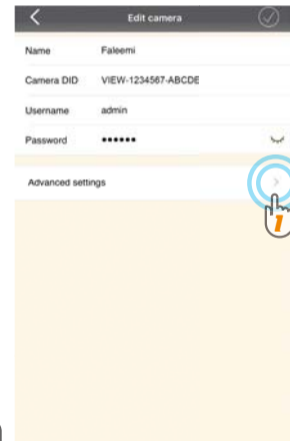

2. Click on [Memory Card Settings].

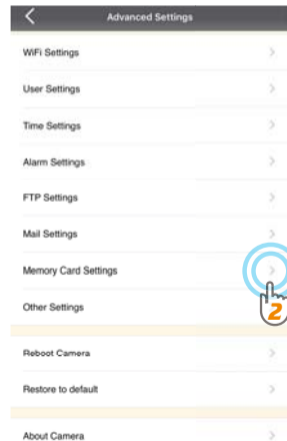

3. Enable [Continuous Recording].

4. Set [Record Time] (15 Mins Max).

5. Click on [✓].

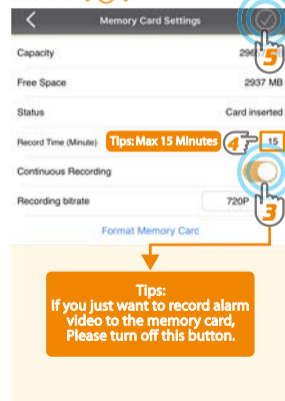

How to record alarm video to the memory card?

1. Click on the icon [>].

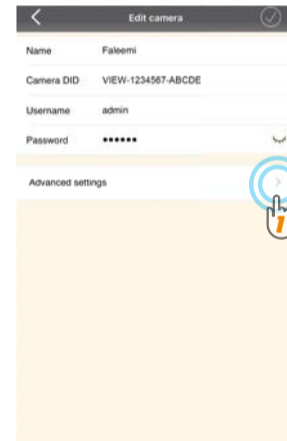

2. Click on [Alarm Settings].

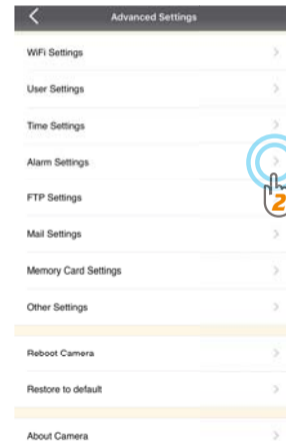

3. Enable [Motion Detect Alarm].

4. Enable [Save Video on the Memory Card].

5. Click on [✓].

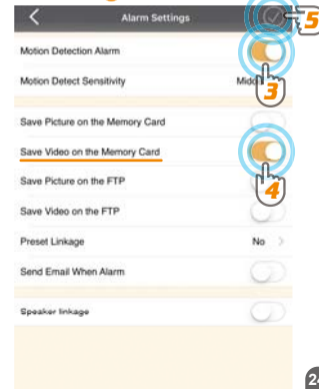

How to view the recorded video on memory card?

1. Click on **[Records]**.
2. Click on **[Memory Card]**.
3. Click on **[Camera]**.



4. Click on **[All]**, Select recording.
5. Select Date.
6. Click on **[☑]**.



7. Click on the file to playback the recorded video.

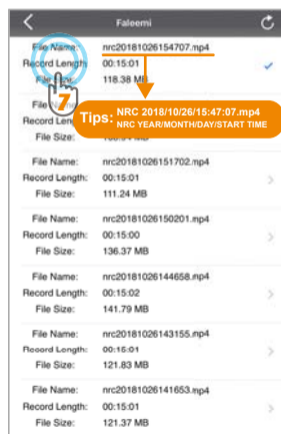

How do i change my camera password?

To ensure the security of your camera, you are suggested changing the default password. 

1. Click on **[>]**.



2. Click on **[Advanced Settings]**.



3. Click on **[User Settings]**.

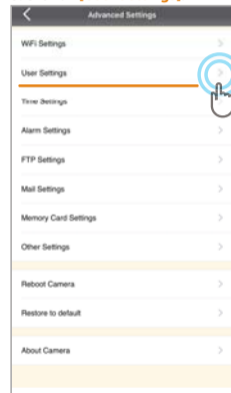

4. Select **[admin]**, Click on **[>]**.

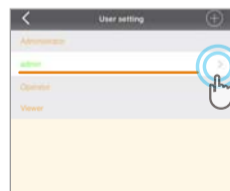

5. Enter your new password, Click on **[☑]**.

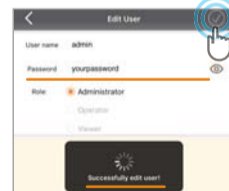

The camera password is only saved in the camera, please keep your password in mind, and if you forget it, you can only reset the camera and reconnect it. **Record your new password here:**

Troubleshooting Frequently Asked Questions

For more setting guides, please visit our website:

<https://www.faleemi.com/faq>

If you don't find the instructions you are looking for there, please contact us at

support@faleemi.com.



<https://www.faleemi.com/faq>

1. How to reset your camera (restore to factory default)?

Push down the "Reset" button for around 10-15 seconds until the green light changes from blinking slowly to very quickly and then let the Reset button go. If the reset is done successfully, the camera will reboot automatically.

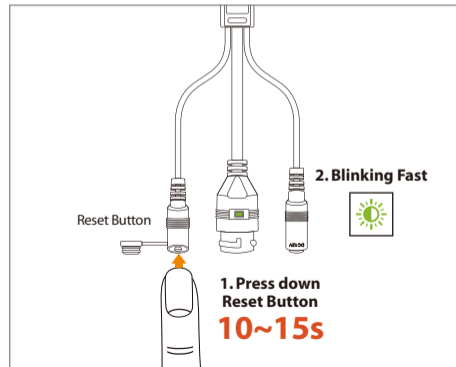

2. If you will be away from your camera for a long time, for example, you will be on holiday for several months, there may be power outage or network disconnection.

We suggest you using Timer Restart option. 

You can set the camera to reboot by itself during this time period.

Please refer to this instruction to do the setup.

<http://support.faleemi.com/help/reboot.pdf>

3. If you have several cameras, please set them up one by one according to the instruction from page 3. After all of them are set up, please follow below steps to use multi-view function.

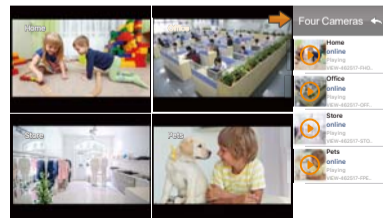

4. How do i change my video stream resolution?

Click on the icon  to change the resolution.



5. I mounted my camera upside down, how do I flip my camera's video stream?

Click on   to flip and mirror your camera.

6. How do I find the WiFi MAC address of my camera?

If you need the WiFi MAC address of the camera to connect it to your router, please take the photo of the label on the camera and send it to support@faleemi.com.

We will provide you with the WiFi Mac address

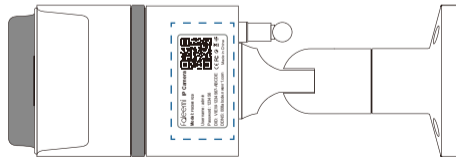

7. If I change the router, how do I reconnect the camera?

A. We recommend that you change the WiFi name (SSID) and password for the new router to the same as the old router, so you don't need to reconnect your camera, please just replug it in and it will be online automatically. So do your other wireless devices.

B. If you can not change the new router WiFi name (SSID) and password, you need to reset the camera (refer to **page 27**) and then reconnect it according to the instructions (**page 3**)

8. How do I change the WiFi SSID on my router?

Windows 7



<https://youtu.be/8gx60SEHSu4>

for more router settings, please visit

<https://www.faleemi.com/blocks/router>

If there is no the guide for your router settings, please email us at support@faleemi.com

Windows 10



<https://youtu.be/V3pgXHvQ67U>



More Router Settings

MAC



<https://youtu.be/qzwRIwLnNPg>

9. How to set Faleemi camera IP Address and Port ?

Please visit <https://youtu.be/2uFUQkM6cBo>



11. How to link your camera to your PC/Mac by Faleemi Plus?

Download Link:

Faleemi Plus for Windows:

http://support.faleemi.com/software/Faleemi_Plus_v1.0.2.exe

Faleemi Plus for Mac:

http://support.faleemi.com/software/Faleemi_Plus_v1.0.2.dmg

10. How to set Email alert?

Please visit

http://support.faleemi.com/mail/Email_alert.pdf

If there is no the guide for your email server,
please email us at support@faleemi.com



Windows:

<https://youtu.be/sEuauwrchbs>

Mac:

<https://youtu.be/pljGg0l86N8>

